

Item Number
RAM-VB-108

RAM No-Drill™ Seat Bases

National Products, Inc.

Vehicle base for the
FORD EXCURSION (2000-2005)
FORD EXCURSION EDDIE BAUER (2000-2005)
FORD F-250 to F-750 SUPER DUTY TRUCKS (1999-NEWER)
FORD F-350 SUPER DUTY TRUCKS (1997)

SPECIFICATIONS

Placement

Passenger side floor board, under seat

Seat Configuration

Bucket/Bench

Construction/Finish

Steel/Black Powdercoat

Dimensions

A = 18.75", B = 5.63", C = 6.437", D = 13.25"
Hole Center = 11.5"

Pole or Pedestal

Purchased Separately

Weight

9.4 lbs.

Features

Installs in minutes with no drilling required

Step feature allows optimized placement of mount with a minimal amount of intrusion of passenger space

Important Note

One Offset Universal Mount step is included with this vehicle base

In the Ford Excursion Limited and Eddie Bauer editions, the heater duct prevents access to left seat stud. The mount can be used by removing the carpet and plugging the heater duct. If this is unacceptable, the RAM-VBD-101 can be used as an alternative.

National Products, Inc.
Phone: 206-763-8361
Fax: 206-763-9615
Address: 1205 S Orr St
Seattle, WA 98108
Website: www.ram-mount.com
Email: staff@ram-mount.com



Shown Assembled

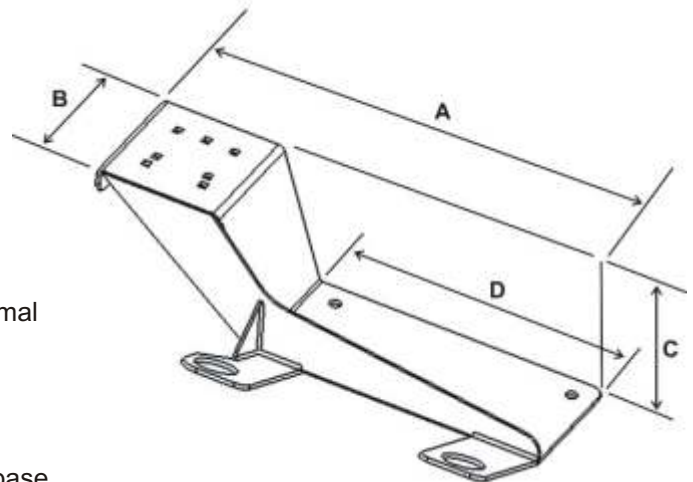

RAM-VB-108



Item Number
RAM-VB-108

RAM No-Drill™ Seat Bases
National Products, Inc.

Vehicle base for the
FORD EXCURSION (2000-2005)
FORD EXCURSION EDDIE BAUER (2000-2005)
FORD F-250 to F-750 SUPER DUTY TRUCKS (1999-NEWER)
FORD F-350 SUPER DUTY TRUCKS (1997)

INSTALLATION INSTRUCTIONS

Bucket Seat Instructions:

1. Remove the front seat bolts from the passenger side of the seat. This may require the use of a T-55 Torx Bit. While lifting the front of the seat, slide the legs of the VB-108 under the passenger seat mounting bracket. Center the legs under the passenger seat mounting bracket and lower the seat back into place. The depressions in the seat legs will locate themselves into the round opening of the no drill base.
2. Re-install the seat bolts to secure the no drill base and seat frame to the floor board. Fully tighten.

Bench Seat Instructions:

1. Remove the front seat bolts from the passenger side of the seat. While lifting the front of the seat, slide the legs of the VB-108 under the passenger seat mounting bracket. Center the legs under the passenger seat mounting bracket and lower the seat back into place.
2. Most Ford floor pans (when used with a bench seat) have a hole in the floor with a welded nut on the underside of the vehicle. This hole is often covered with a plastic plug. If there is no hole previously placed in the floorpan from the factory, you must drill a hole.
3. Cut a small hole in the floor covering and remove the plastic plug.
4. Place the included bench seat washer in the hole of the inner leg of the VB-108. Aline the hole in the spacer with the hole in the floor.
5. Fasten down the inner leg of the VB-108 with the M12 X 38MM long bolt, and bench seat washer that was supplied in the hardware bag. If you had to drill a hole in the floor you will need to fasten down the base with a fender washer and lock nut on the under side of the vehicle.
6. Fasten the passenger seat and the outer leg of the VB-108 with the seat bolt you removed earlier.

National Products, Inc.
Phone: 206-763-8361
Fax: 206-763-9615
Address: 1205 S Orr St
Seattle, WA 98108
Website: www.ram-mount.com
Email: staff@ram-mount.com

