

**Item Number** \_\_\_\_\_

RAM-VB-119 &amp; RAM-VB-119-SW1

**RAM No-Drill™ Seat Bases**

National Products, Inc.

**Vehicle base for the  
FORD ECONOLINE VAN (1995-2012)****SPECIFICATIONS****Placement**

Attaches to the passenger side inner front and back seat studs

**Drilling Required**

No - uses existing seat bolts

**Seat Configuration**

Bucket

**Construction/Finish**

Steel/Black Powdercoat

**Pole or Pedestal**

Included on base

**Weight**

10.5 lbs.

**Dimensions**

A = 16.75", B = 8.25", C = 18.75", Hole Center = 13.5"

**Tools required for base installation**

18mm socket or T-55 torx for base installation.

7/16" box end wrench to attach stabilizer

Tools for complete system assembly: pliers, phillips screw driver,  
#10, 1/2", 9/16" box end wrench's.**Features**

Supplied stabilizer is used to brace the base against passenger side seat for added rigidity. Lifetime warranty!

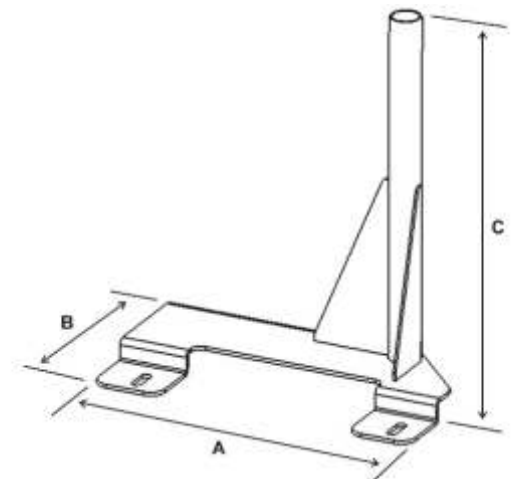
Complete Vehicle Mount  
RAM-VB-119-SW1RAM-VB-119  
Supplied stabilizer not shown**National Products, Inc.**

8410 Dallas Ave S

Seattle, WA 98108

Phone: (206) 763-8361

Fax: (206) 763-9615

Website: www.ram-mount.com

Email: staff@ram-mount.com



**Item Number** \_\_\_\_\_

RAM-VB-119 &amp; RAM-VB-119-SW1

**RAM No-Drill™ Seat Bases**

National Products, Inc.

**Vehicle base for the  
FORD ECONOLINE VAN (1995-2012)****INSTALLATION INSTRUCTIONS**

The RAM-VB-119 No-Drill™ base installs on the inside of the passenger seat with the pedestal forward. The inner front and inner rear seat frame bolts secure the base in place. Use the supplied stabilizer brace for added rigidity as needed.

Tools needed for installation are 7/16" box end wrench, T-55 torx bit, and 18mm deep socket, socket wrench.

1. An "L" shaped stabilizer is included with this kit. One of the gussets has a mounting hole and slot to accommodate this bracket. Attach this prior to installing the base into the vehicle. Leave the bracket just loose and do the final adjustment once the base is installed and seat frame fully tightened to floor board. Using the supplied 1/4-20 hardware, attach the bracket to the base with the 7/16" box end wrench. The part number for this kit is RMR-HAR-VB-119. Kit includes hardware and "L" bracket only.
2. Using the 18mm deep socket and T-55 torx bit, loosen and remove the hardware holding the seat frame to the floor board.
3. Raise the inside of the seat frame off of the floor enough to allow the No-Drill™ base to be placed over the hole and stud now exposed on the vehicle floor. Placement is between the seat frame and floor board, inside front and inside rear of passenger seat hardware.
4. Gently lower seat back into place so that the No-Drill™ base is between the seat frame and floor board.
5. Re-install the previously removed hardware and fully tighten to 39 ft lbs.



**National Products, Inc.**  
8410 Dallas Ave S  
Seattle, WA 98108  
Phone: (206) 763-8361  
Fax: (206) 763-9615  
Website: [www.ram-mount.com](http://www.ram-mount.com)  
Email: [staff@ram-mount.com](mailto:staff@ram-mount.com)

